15 kV and 25 kV CLASS FUSED LOADBREAK ELBOW INSTALLATION & OPERATING INSTRUCTIONS

DESCRIPTION

The CHARDON Loadbreak Fused Elbow Connector is a fully-shielded, submersible, and insulated plug-in termination with full range current-limiting fuse protection. It is used for connecting underground cable to transformers, switching cabinets and junctions equipped with loadbreak bushings. The fused elbow connector and bushing insert comprise the essential components of all loadbreak connections. The elbow interface of the bushing insert meets the requirements of ANSI/IEEE 386 as defined below:

- 15kV 200A Class (8.3kV and 8.3/14.4kV)
- 25kV 200A Class (15.2kV and 15.2/26.3kV)

FUSED ELBOW KIT CONTENT:

- 1 - Elbow Body (top half)
- 1 - Straight Body (lower half)
- 1 - Compression Connector (Cooper or Elastimold Type)
- 1 - Probe Connector (Cooper or Elastimold Type)
- 1 - Probe Connector Wrench (1/8" Hex Wrench)
- 1 - Loadbreak Probe
- 1 - Probe Wrench (Probe Installation Tool)
- 2 - Lubricant
- 2 - Paper towel
- 1 - Installation Instructions



CAUTION: All associated apparatus must be de-energized during installation and/or maintenance.



DANGER: Do not touch or move energized product by hand. Failure to follow this instruction may result in serious or fatal injury, as well as damage to the product.

SAFETY INFORMATION

The instructions in this manual are not intended as a substitute for proper training or adequate experience in the safe operation of the equipment described. Only competent technicians, who are familiar with this equipment should install, operate and service it.

INSTALLATION PROCEDURE

STEP 1

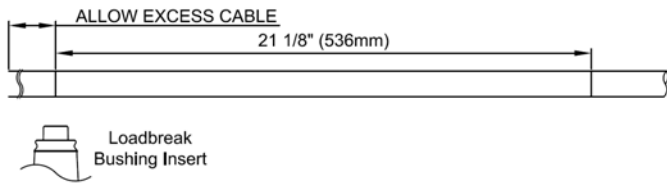

Position cable vertically so that it is centered on apparatus bushing and parallel to the apparatus frontplate. Make square cut at cable to the centerline of bushing.

STEP 2

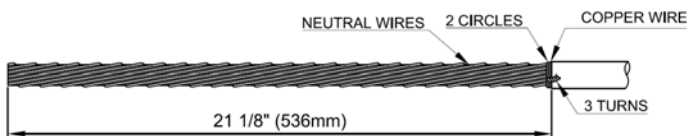

Measure down from top of the cable 21 1/8". Remove cable jacket (if jacketed cable is used) to expose neutral wires. Provide sufficient length of neutral wires for grounding after installation. Use copper wire to secure neutral wires to insulation shield of cable as shown.

STEP 3



Bind end of cable jacket with mastic.

STEP 4

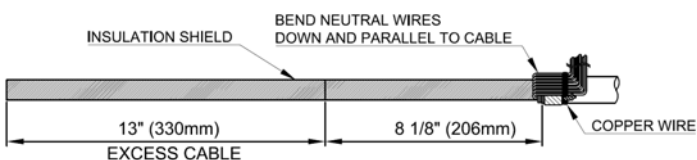

- Unwind neutral wires.
- Bend Neutral wires down and parallel to cable.
- Use copper wire to secure neutral wires to cable jacket as shown.
- Make square cut from top of the cable 13".

STEP 5

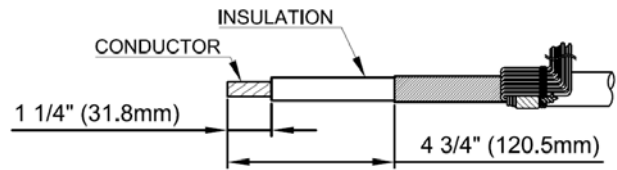

- Measure down from the top of the cable 4 3/4". Remove the conductor shield to expose the insulation. Take care not to nick the insulation.
- Measure down from the top of the cable 1 1/4". Remove the insulation to expose the bare conductor. Take care not to nick the conductor.

STEP 6

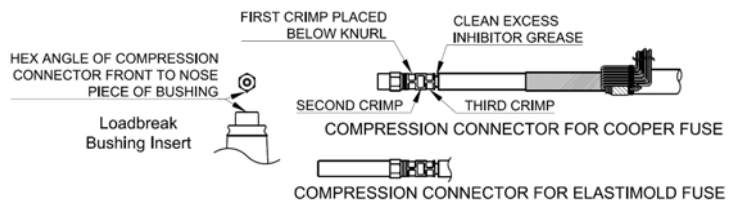

- Clean the exposed conductor using a wire brush. Place the compression connector on the conductor. Make sure the hex angle of compression connector front to nose piece of apparatus bushing.
- See Table for recommended crimp tools and dies.
- Rotate the tool between each successive crimp to prevent connector distortion.
- Re-align the connector with the cable to eliminate any bends caused by crimping.
- Clean excess grease from bi-metal connector by wiping toward threaded eye.

STEP 7

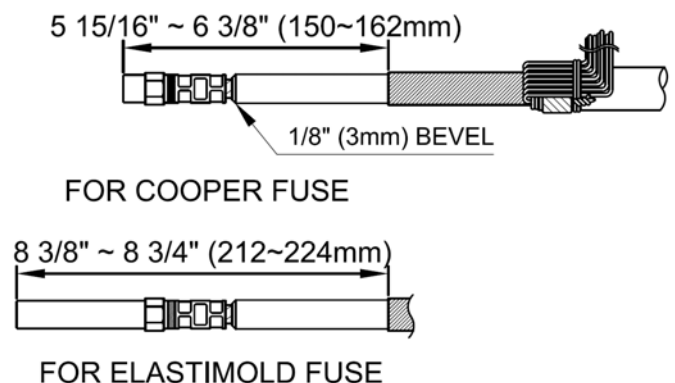

Place a 1/8" maximum bevel on the insulation to ease elbow installation.

STEP 8

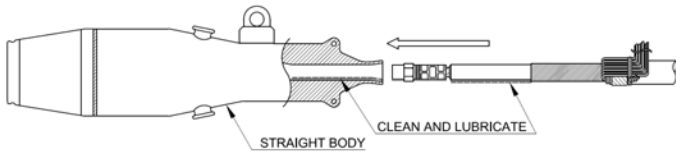

- Clean and lubricate by supplied lubricant to cable and straight body as show.
- Slide the straight body onto the cable, using a back and forth twisting motion, and final seating of the straight body should align the hexagonal metal and connector.

STEP 9

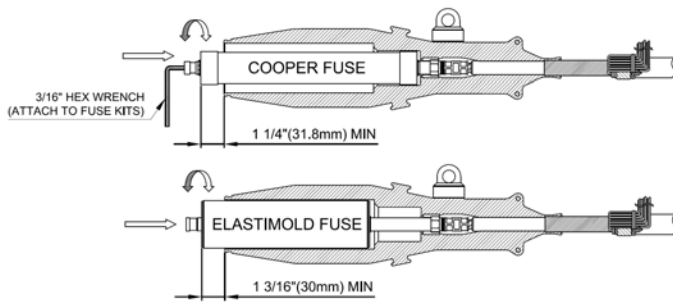

- Slide the fuse into the straight body and insert fuse threaded end first.
- Thread fuse clockwise by hand or hex wrench until tight. Confirm check dimension as show.

STEP 10

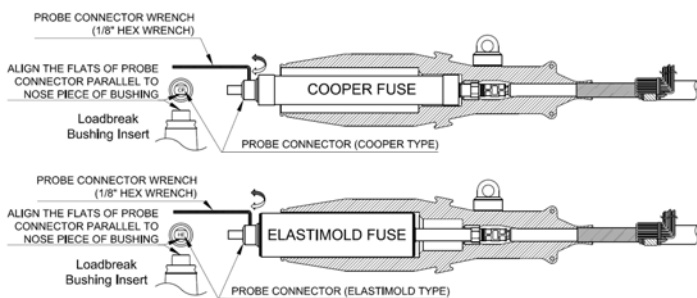

- Slide the probe connector onto the fuse. Make sure the align the flats of probe connector parallel to nosepiece of apparatus bushing.
- Using supplied probe connector wrench, thread the two set screws until they bottom out on the end post of the fuse, then tighten each set screw an additional 1/8-1/4 turn until tight.

STEP 11

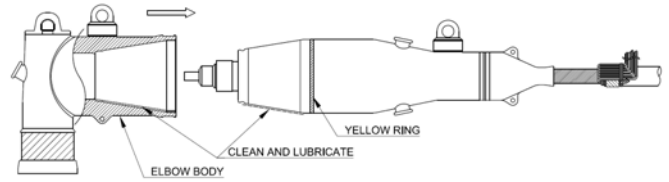

- Clean and lubricate by supplied lubricant to elbow body and straight body as show.
- Slide the elbow body onto the fuse, using a back and forth twisting motion until cover yellow ring.

STEP 12

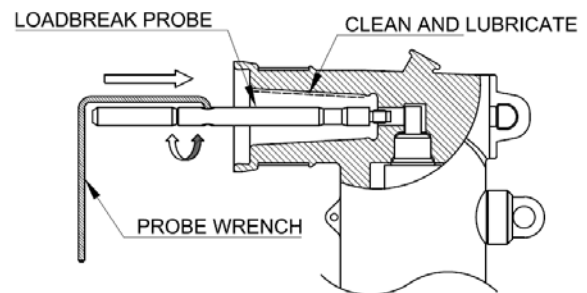

- Turn the elbow body until the loadbreak probe can be assembled into the probe connector.
- Insert the loadbreak probe into the probe connector and hand tighten several turns to avoid cross threading; then tighten with probe wrench provided until the wrench permanently deforms. (Then discard the wrench.)
- If other tightening tools are used, they should produce a torque exceeding a minimum recommended 110 inch-pounds for the loadbreak probe to connector tightening.
- Keep the loadbreak probe free of dirt at all times.

STEP 13

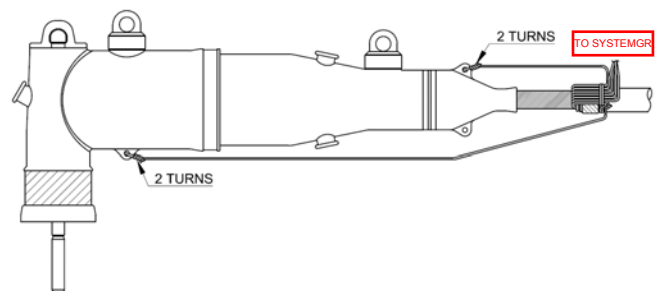

Using one or more neutral wires, connect the concentric neutral to the elbow body and straight body grounding tab near the cable entrance. A tight connection will provide positive grounding for the elbow body and straight body shield.

OPERATING INSTRUCTIONS

Do not connect two different phases of a multiple-phase system. Before closing a single-phase loop, make certain both ends of the loop are the same phase.

Loadmake Operation

- Area must be clear of obstructions or contaminants that would interfere with the operation of the loadbreak elbow.
- Securely fasten a suitable live-line tool to the pulling eye.
- Place the load break elbow over the bushing, inserting the white arc follower of the probe into the bushing approximately 2 1/2" until a slight resistance is felt.
- Immediately thrust the elbow onto the bushing with a fast, firm, straight motion, with sufficient force to latch the elbow to the bushing.
- Push again on the live-line tool, then pull gently to make sure it is secure.

Fault Close :

- It is not recommended that operations be made on known faults.
- If a fault is experienced, both the elbow connector and the bushing must be replaced.

Loadbreak Operation

- Securely fasten a suitable live-line tool to the pulling eye.
- Without exerting any pulling force, slightly rotate the connector clockwise to break surface friction between the elbow and bushing.
- Withdraw the connector from the bushing with a fast, firm, straight motion, being careful not to place the connector near a ground plane.
- Place connector on an appropriate accessory device, following the operating instructions for that accessory.
- Place an insulated protective cap with drain wire attached to system ground on any exposed energized bushing using a live-line tool.

TABLE
Crimp Chart

CONNECTOR	CONDUCTOR SIZE	BURNDY			Thomas and Betts		KEARNEY		ACA Conductor Accessories		Anderson Tool	Edison Electric Institute REDERENCE	
		TOOL	DIE		TOOL	DIE	TOOL	DIE	TOOL	DIE			
5/8" DIAMETER	NO. 4 THRU 2/0 STRANDED	Y34	A243 (2)	A25AR (2)	UT-3	5/8" (4)	O	5/8" NOSE (4)	12 A	B24 EA (2)	VC-5 VC-6	8A	
		Y35 OR Y39	U243 (2)	U25ART (2)	UT-5	TV (4)		9/16" (3)					
			UBG (2)	U687 (2)				9/16" (2)					
		MD6	W243 (2)	BG(3) NOSE (2)	UT-15	54H (2)	WH2,WH3,BH4, WH4,PH2,PH13	572 (2)					
			WBG (2)	W687 (2)									
3/4" DIAMETER	3/0 - 4/0 STRANDED	Y34	U247 (2)	A27AR (2)	UT-5	TV (4)	O	737 (3)	12 A	B39 EA (2)	VC-5 VC-6	10A	
		Y35 OR Y39	U247 (2)	U27ART (1)				747 (2)					
			U467 (2)				737 (3)						
		MD6	W247 (2)		UT-15	66 (2)	WH2,WH3,BH4, WH4,PH2,PH13	747 (2)					

These instructions do not purport to cover all details or variations in equipment, nor to provide for every possible contingency, to be met in connection with installation, operation or maintenance. Should further information be desired, or should particular problems arise which are not covered sufficiently, please contact the Chardon Group.

Inasmuch as CHARDON GROUP, Inc. has no control over the use which others may put the material, it does not guarantee that the same results as those described herein will be obtained, Each user of the material should make his own tests to determine the material's suitability for his own particular use. Statements concerning possible uses of the materials described herein are not to be construed as constituting a license under any CHARDON GROUP, inc. patent covering such use or as recommendations for use of such materials in the infringement of any patent.

FOR FURTHER INFORMATION WRITE TO



sales@chardongroup.com