

---

## 35 kV 600A CLASS ELBOW INSTALLATION & OPERATING INSTRUCTIONS

---

### DESCRIPTION

The CHARDON 600A class deadbreak elbow connector used to terminate high-voltage cable on dead front apparatus transformers and switchgear or make separable splice or junction connections. They are fully shielded, fully submersible and are interchangeable with all other manufacturers that certify compliance with IEEE standard 386.

- 35kV 600A Class (21.1kV)

### ELBOW KIT CONTENT:

Elbow  
Compression Lug  
Cable Adapter  
Stud  
Insulating Plug  
Conductive Cap  
Silicone Lubricant  
Paper Towel  
Installation Instructions



**CAUTION:** All associated apparatus must be de-energized during installation and/or maintenance.

---



**DANGER:** Do not touch or move energized product by hand. Failure to follow this instruction may result in serious or fatal injury, as well as damage to the product.

---

---

### SAFETY INFORMATION

The instructions in this manual are not intended as a substitute for proper training or adequate experience in the safe operation of the equipment described. Only competent technicians, who are familiar with this equipment should install, operate and service it.

---

# INSTALL PROCEDURE

## STEP 1

Check kit components to insure proper fit with the cable diameter dimensions, conductor size, and mating products.

## STEP 2

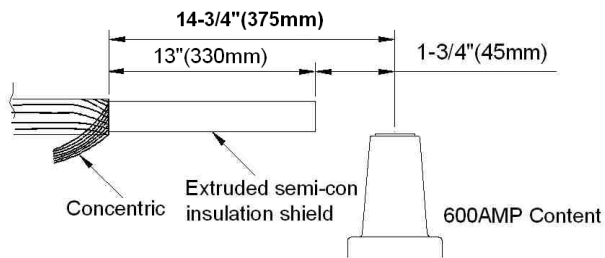

Measure down from top of the cable 14-3/4" (375mm). Remove cable jacket (if jacketed cable is used) to expose neutral wires. Cut cable 1-3/4" (45mm) from the centerline of the mating bushing. Clean the Extruded semi-conductor insulation shield.

## STEP 3

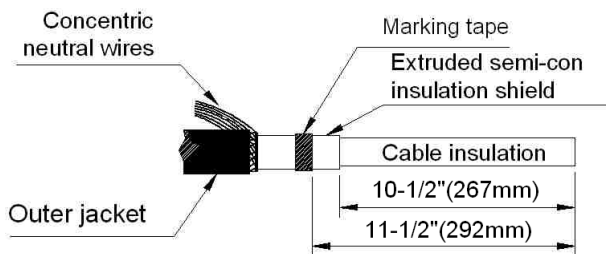

Remove the outer jacket 10-1/2" (267mm) from the end of cable. Use a Marking tape to take out of the semi-conductor insulation shield 11-1/2" (292mm) from the end of the cable.

## STEP 4

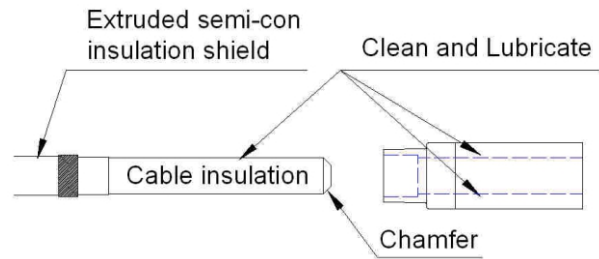

Thoroughly clean the insulation with a solvent dampened cloth, wiping from conductor toward cable semi-con shield. Ensure that all traces of conductive residue are removed, then clean and lubricate surface of bare conductor, inside of cable adapter, install cable adapter.

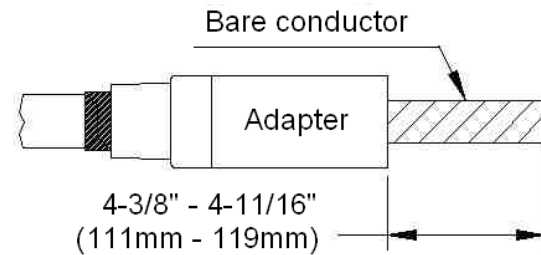

Remove insulation exposing conductor between 4-3/8" (111mm) and 4-11/16" (119mm), and chamfered the end of the cable. Take care not to nick the conductor.

## STEP 5

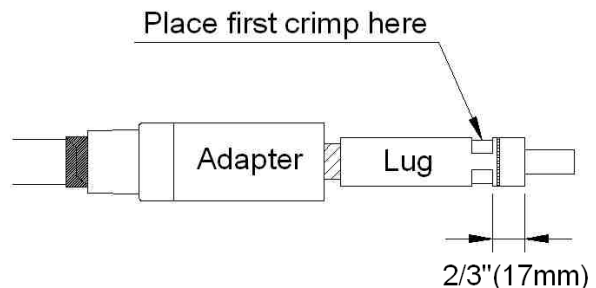

Remove protective cap and fully insert conductor into compression lug. Connector must be fully seated on cable conductor. Align flats of lug and bushing before crimping. Start crimps at the lug end 2/3" (17mm) below shoulder of compression connector and work down. Crimp the compression lug following the

crimp instruction supplied with the lug. Wipe all excess inhibitor from connector and cable adapter surfaces.

### STEP 6

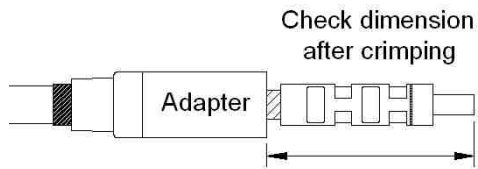

6-1/2" - 7-1/4" (165mm-184mm)

- Make sure the distance from the end of the lug to the cable adapter after crimping should be between 6-1/2" (165mm) to 7-1/4" (184mm). Otherwise redo assembly.
- Clean the exposed conductor using a wire brush.
- Place the bi-metal connector on the conductor. Make sure the threaded hole in connector faces the apparatus bushing.
- See Table for recommended crimp tools and dies.
- Rotate the tool between each successive crimp to prevent connector distortion.
- Re-align the connector with the cable to eliminate any bends caused by crimping.
- Clean excess lubricant from connector by wiping toward threaded eye.

### STEP 7

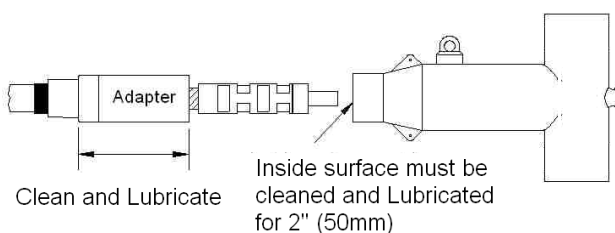

Clean and evenly lubricate the entire surface of cable adapter with silicone lubricant. Lubricate inside the cable entrance of the elbow at least 2" (50 mm) deep. If test point elbow is used, ensure that test point is facing towards installer. Slide the elbow onto the cable, using a back and forth twisting motion, and final seating of the elbow should align elbow and connector.

### STEP 8

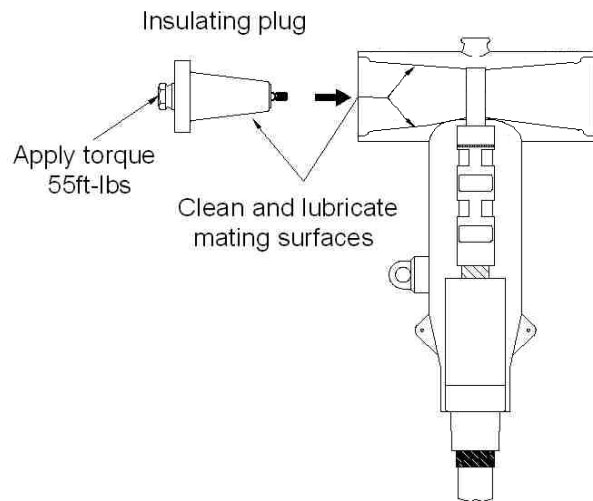

Hands tighten the threaded stud into the insulating plug or mating part. Push plug into the elbow and tighten to apparatus bushing using a torque wrench and 1" socket. Tighten plug clock-wise exerting 55 ft-lbs (75N-m) of torque. The insulating plug provides a capacitive test point for detecting system voltage.

### STEP 9

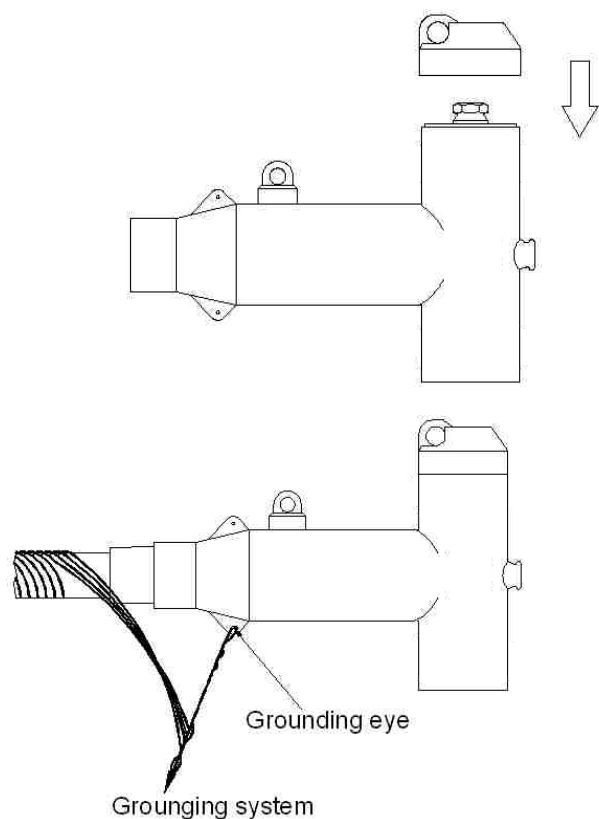

Connect grounding eye of elbow with a drain wire to cable concentric neutral wires or to common ground point..

## STEP 10

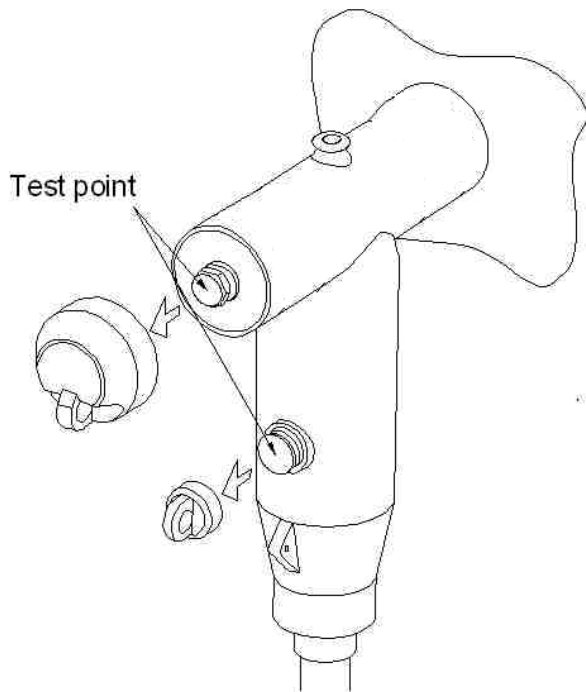

- Remove test point cap with a hot stick. Rather than pulling directly in line with the test point assembly.
- Using a suitable sensing device, determine if the cable is energized.
- After voltage detection has been made, replace it on the test point with a hot stick.

Inasmuch as CHARDON GROUP, Inc. has no control over the use which others may put the material, it does not guarantee that the same results as those described herein will be obtained, Each user of the material should make his own tests to determine the material's suitability for his own particular use. Statements concerning possible uses of the materials described herein are not to be construed as constituting a license under any CHARDON GROUP, inc. patent covering such use or as recommendations for use of such materials in the infringement of any patent.

---

FOR FURTHER INFORMATION WRITE TO



[sales@chardongroup.com](mailto:sales@chardongroup.com)

**TABLE  
Crimp Chart**

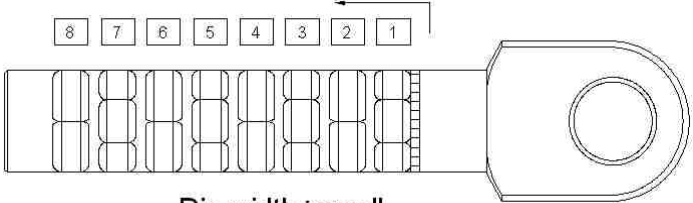
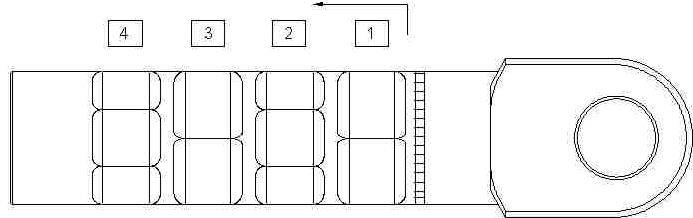
Material	Cable sections (mm <sup>2</sup> )	DIN ( Hexagonal Crimp)			Drawing
		Die index	Die width small	Die width large	
Copper	16	8	8	---	 <p align="center">Die width : small</p>
	25	10	8	---	
	16-25-35	12	8	---	
	50	14	8	---	
	70	16	8	---	
	95	18	8	4	
	120	20	8	4	
	150	22	8	4	
	185	25	8	4	
	240	28	---	4	
	300	32	---	4	
	400	38	---	4	
	500	42	---	4	
	650	44	---	4	
Aluminum	25-35-50	12	8	4	 <p align="center">Die width : large</p> <p align="center">Rotate each successive crimp 90° and remove flashes resulting from crimping.</p>
	35	14	8	4	
	50	16	8	4	
	70	18	8	4	
	95	22	8	4	
	120	22	8	4	
	150	25	8	4	
	185	28	8	4	
	240	32	8	4	
	300	34	8	4	
	400	38	---	4	
	500	44	---	4	

*These instructions do not purport to cover all details or variations in equipment, nor to provide for every possible contingency, to be met in connection with installation, operation or maintenance. Should further information be desired, or should particular problems arise which are not covered sufficiently, please contact Chardon Group.*

