

---

42 kV 1250A IEC Front / Coupling (Rear)  
T-Body Connector  
INSTALLATION & OPERATING INSTRUCTIONS

---

DESCRIPTION

The CHARDON 42 kV 1250A IEC front / coupling (rear) T-body connectors are used to terminate polymeric cable to equipment, such as transformers, switchgear, motors etc. equipped with bushings meeting type C interface per CENELEC EN 50180 and 50181. They are fully screened and fully submersible when mated with the proper bushing or plug and they meet the requirements of CENELEC HD 629.1 S2.

- 42kV 1250A Class (20.8/36kV)

Front T-body Kit Content:	Coupling T-body Kit Content:
⊙ - Front T-body	⊙ - Coupling (rear) T-body
⊙ - Compression Lug	⊙ - Compression Lug
⊙ - Cable Adapter	⊙ - Cable Adapter
⊙ - Stud	⊙ - Stud
⊙ - Washer	⊙ - Connecting rod
⊙ - Hex nut	⊙ - Silicone Lubricant
⊙ - Insulating Plug	⊙ - Paper Towel
⊙ - Conductive Cap	⊙ - Installation Instructions
⊙ - Silicone Lubricant	
⊙ - Paper Towel	
⊙ - Installation Instructions	



**CAUTION:** All associated apparatus must be de-energized during installation and/or maintenance. Indicates a hazardous situation which, if not avoided, could result in minor or moderate injury.

---



**DANGER:** Do not touch or move energized product by hand. If not avoided, will result in death or serious injury.

---

SAFETY INFORMATION

The instructions in this manual are not intended as a substitute for proper training or adequate experience in the safe operation of the equipment described. Only competent technicians, who are familiar with this equipment should install, operate and service it.

---

# INSTALLATION PROCEDURE

## STEP 1

Check kit components to insure proper fit with the cable diameter dimensions, conductor size, and mating products.

## STEP 2

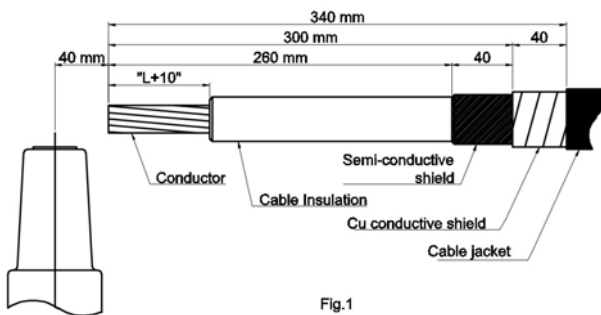

Prepare the cable to the desired finished position and cut the cable. (See Fig. 1)

- 1) Remove the cable jacket for a distance of 340 mm from the end of the cable. Remove the copper conductive shield for a distance of 300 mm from the end of the cable. Do not damage the semi-conductive shield.
- 2) Remove 260 mm of insulation screen. Do not damage the cable insulation.
- 3) Remove L+10 mm of cable insulation. L is depth of compression lug. Use PVC tape to secure the exposed ends of the cable conductors.
- 4) At the end of the insulation and semi-conductive shield chamfer the sharp end at a 45° angle.

## STEP 3

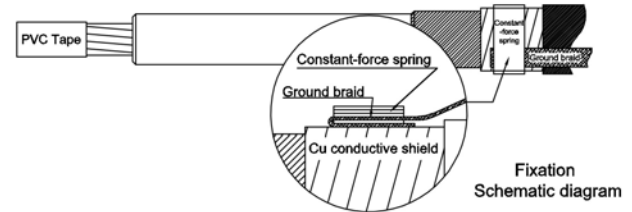

Fig.2

Single core cables need to ground by ground braid. Fix ground braid by constant-force spring on copper conductive shield of cable as shown in Fig. 2.

## STEP 4

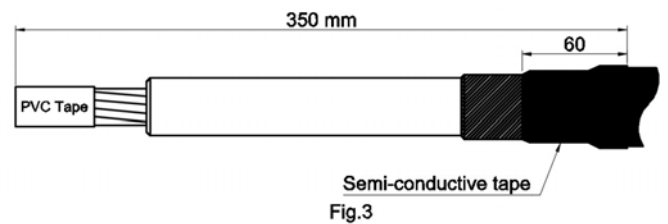

Fig.3

Wrap 2 layers a distance of 60mm of the semi-conductive tape for a distance of 350mm from the end of cable, copper conductive shield and semi-conductive shield as shown in Fig. 3.

## STEP 5

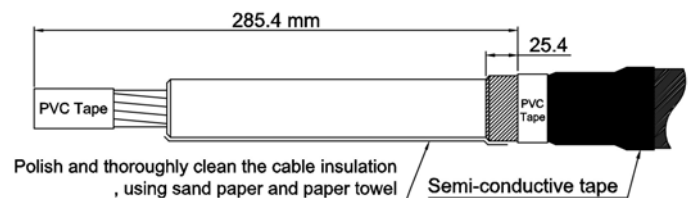
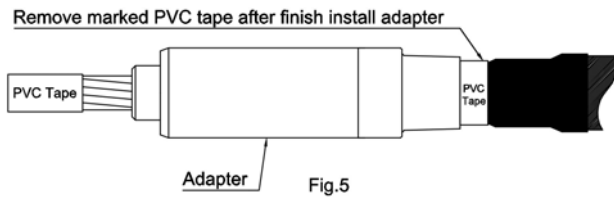

Fig.4

Polish and thoroughly clean the cable insulation, using sand paper and paper towel. Wrap two turns of PVC tape to serve as a marker at a position of 25.4 mm from end of the insulation screen (a distance of 285.4 mm from the end of the cable, See Fig. 4).

## STEP 6



Lubricate the exposed cable insulation and adapter inside interface. Slide the cable adapter onto the cable, black end first, until the black end is flush with tape marker. Check the Critical Dimension as shown in Fig. 5 below. Then remove the marker. Wipe off grease from end of cable adapter, preparing the surface for application of tape.

## STEP 7

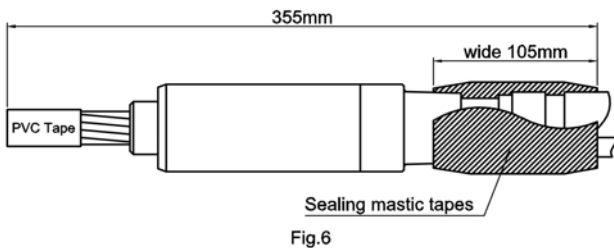

Wrap 2 layers of sealing mastic tape 355mm from the end of cable (wide 105mm). Wrap 2 layers of PVC tape on the sealing mastic tapes. (See Fig. 6)

## STEP 8

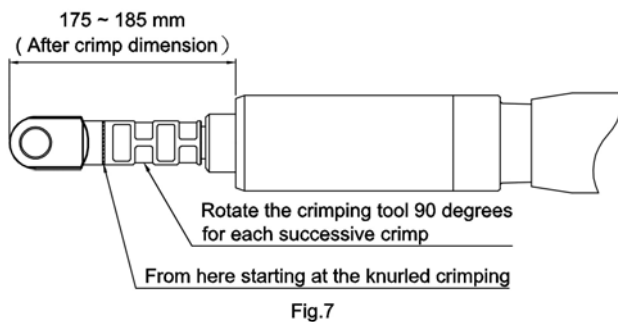

Remove the PVC tape and clean conductor from the end of the conductor. Immediately insert the conductor into the crimping barrel as far as it will go. Ensure that the flat of the lug spade is parallel to the face of the bushing. Stress from the tail cone to the crimp terminals 175 ~ 185mm at the top of the crimp terminals

installed, and crimp the lug starting at the mark on the barrel of the knurled end of the lug as shown in Fig. 7. Rotate the crimping tool 90 degrees for each successive crimp. Remove any excess inhibitor that may have come out of the crimp lug. File off any sharp projections.

## STEP 9

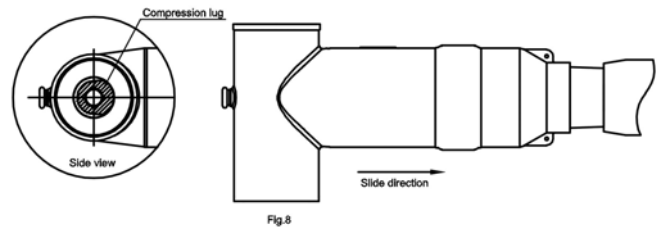

Clean the outer surface of the cable adapter and the interior of the cable entrance of the front T-body with a lint-free cloth. Apply a thin layer of lubricant to both surfaces. Push the front T-body over the cable adapter as far as it will go. Ensure that the hole in the top of the crimp connector is visible through the interface end of the T-body. (See Fig. 8)

## STEP 10

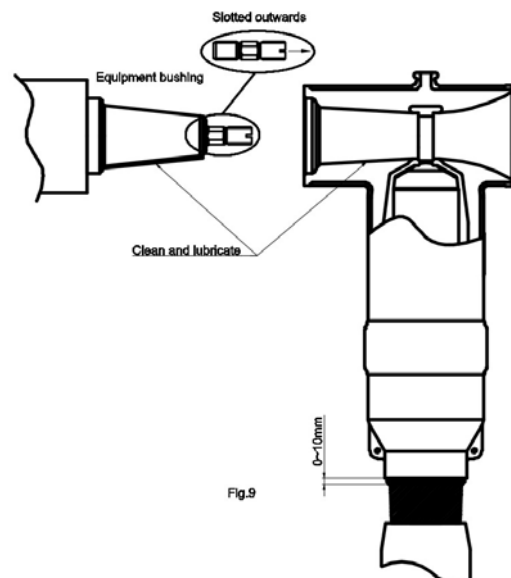

Tighten the stud to 55 Nm, using a 14 mm open end wrench. (Slotted outwards) Clean equipment bushing and front T-body interface. Wait for cleaning solvent to evaporate. Lubricate both interfaces. (See Fig. 9)

**Installing check:** After installing, check the dimension of the end of front T-body and adapter step. It should be 0~10mm. If it is over 10 mm, check the installation dimensions or reinstall all parts.

STEP 11

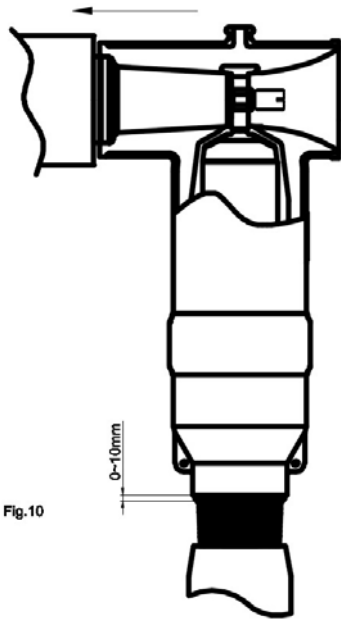

Fig.10

Push the front T-body onto the equipment bushing. Make sure the stud passes through the hole in spade of lug. (See Fig.10)

STEP 12

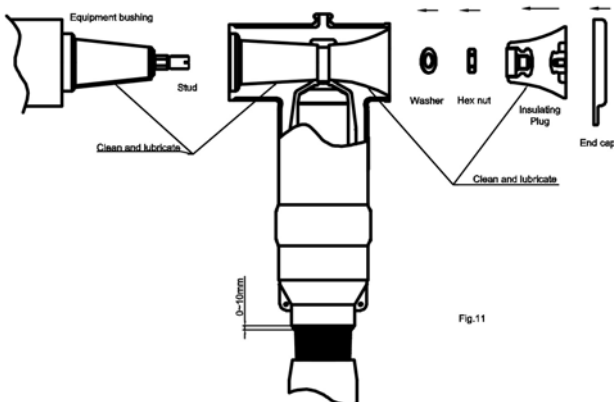

Fig.11

Put washer and hex nut on the stud, and tighten the nut to 50-55 Nm, using a torque wrench and a 24 mm socket. Clean the insulating plug and

front T-body interfaces with cleaning wipes. Wait for the cleaning solvent to evaporate. Apply a thin layer of lubricant to both surfaces. Insert the insulating plug into the front T-body and engage the threads of the threaded stud. Tighten the insulating plug to 35-40 Nm, using a torque wrench and 24 mm socket. (See Fig.11)

STEP 13

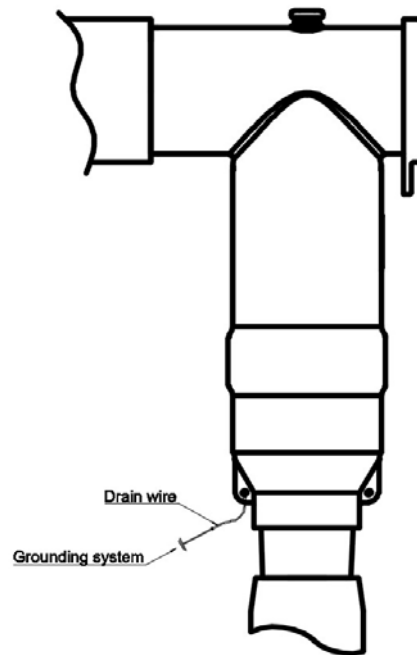

Fig.12

Clean the interior surface of the rubber cap. Place it over the insulating plug and push it until it snaps into place. Connect drain wire on front T-body to the grounding system. (See Fig.12)

**CAUTION: A connector/bushing mated combination should not be allowed to carry the full weight of the cable. Therefore it is necessary to clamp the cable as close as possible to the connector.**

## STEP14

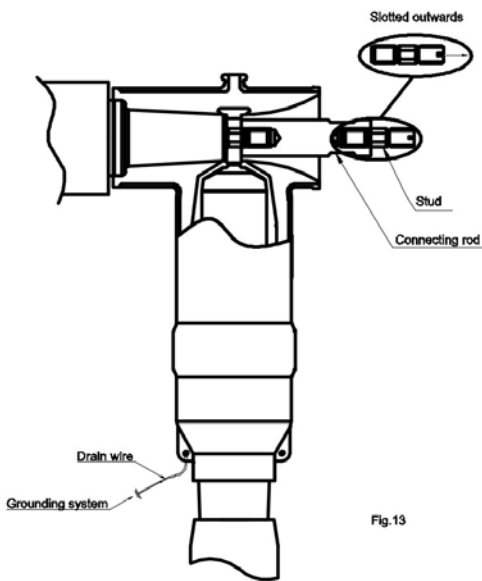

Fig.13

### IEC Coupling (Rear) T-body Instructions:

**Step 1.** Before install coupling (rear) T-body, complete step 1 to step 11 of front T-body instructions. If front T-body was installed completely, remove insulating plug, nut and washer.

**Step 2.** Install the rod and stud assembly by hand in the front T-body. Make sure the stud in the equipment bushing passes through the hole in spade of the connector.

**Step 3.** Tighten the rod and stud assembly to approximately 50-55 Nm, using a 27 mm open end wrench. (See Fig. 13) (Slotted outwards)

**Step 4.** Repeat Steps 1 to Step 9, prepare cable and install bolted companion coupling (rear) T-body connector. (See Fig. 14)

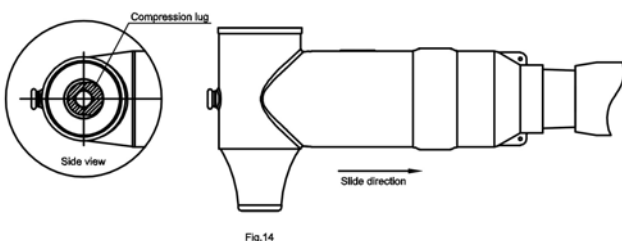

Fig.14

**Step 5.** Clean the interface of companion front T-body connector and coupling (rear) T-body connector with an ISO wipe. Wait for the cleaning solvent to evaporate. Apply a thin layer of lubricant to both interfaces. Slide the bolted companion coupling (rear) T-body connector over the rod and stud assembly and into the front T-body connector.

**Step 6.** Put the hex nut onto the rod and stud assembly and tighten to 50-55 Nm using a 24 mm socket and a torque wrench.

**Step 7.** Clean the insulating plug and the companion coupling (rear) T-body interfaces with an ISO wipe. Wait for the cleaning solvent to evaporate. Apply a thin layer of lubricant to both surfaces.

**Step 8.** Insert the insulating plug into the back of the companion coupling (rear) T-body and engage the threads of the threaded stud. Tighten the insulating plug to 35-40 Nm, using a 24 mm socket and a torque wrench.

**Step 9.** Clean the interior surface of the rubber cap. Place it over the insulating plug and push it until it snaps into place.

**Step 10.** Connect drain wire on front T-body /companion coupling (rear) T-body to grounding system. Clamp the cable below cable jacket seal. (See Fig. 15)

**CAUTION:** A connector/bushing mated combination should not be allowed to carry the full weight of the cable. Therefore it is necessary to clamp the cable as close as possible to the connector.

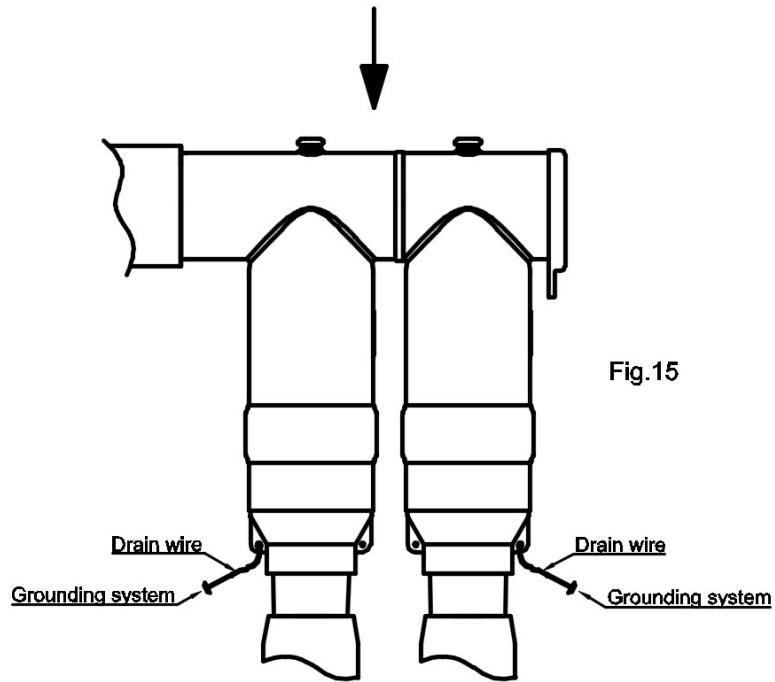
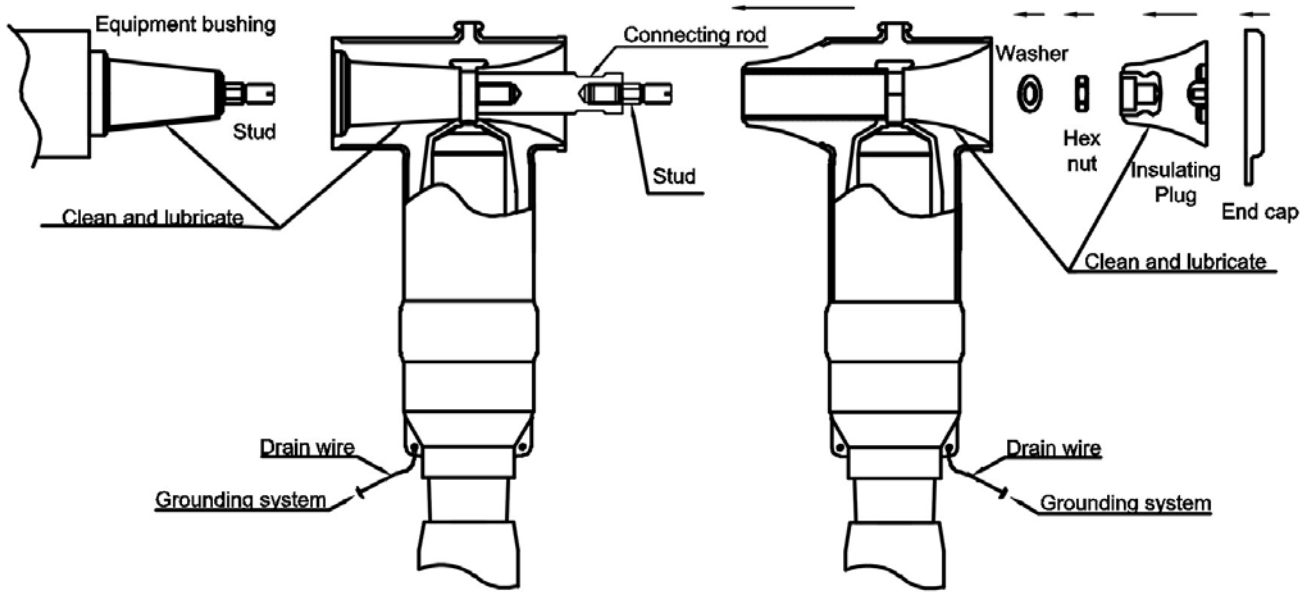

Fig.15

Inasmuch as CHARDON GROUP, Inc. has no control over the use which others may put the material, it does not guarantee that the same results as those described herein will be obtained, Each user of the material should make his own tests to determine the material's suitability for his own particular use. Statements concerning possible uses of the materials described herein are not to be construed as constituting a license under any CHARDON GROUP, inc. patent covering such use or as recommendations for use of such materials in the infringement of any patent.

FOR FURTHER INFORMATION WRITE TO



[sales@chardongroup.com](mailto:sales@chardongroup.com)