

---

## CHARDON SUBMERSIBLE LOW VOLTAGE CONNECTOR INSTALLATION & OPERATING INSTRUCTIONS

---

### DESCRIPTION

The CHARDON submersible low voltage connector meets the requirements of ANSI C119.1, ANSI 119.4 standards. The design incorporates aluminum alloy for reliable conductivity and part strength. The adaptable cable sleeves (Rocket) design allows application on a wide range of conductor sizes. High Quality EPDM insulation rubbers provide excellent resistance to UV, Ozone, Acids and Alkalis.



### LOW VOLTAGE CONNECTOR KIT CONTENT:

- Submersible Low Voltage Connector
- Instruction Sheet
- Lubricant
- Paper Towel



#### CAUTION

All associated apparatus must be de-energized during installation and/or maintenance.



#### DANGER

Do not touch or move energized product by hand. Failure to follow this instruction may result in serious or fatal injury, as well as damage to the product.

---

---

### SAFETY INFORMATION

The instructions in this manual are not intended as a substitute for proper training or adequate experience in the safe operation of the equipment described. Only competent technicians, who are familiar with this equipment should install, operate and service it.

---

# INSTALL PROCEDURE

## STEP 1

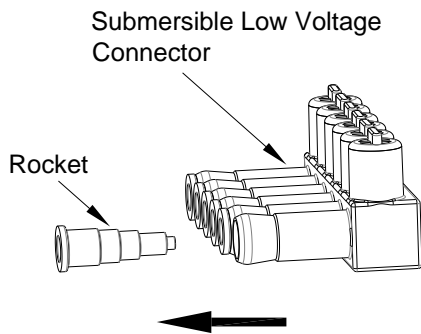

- Remove the rocket (the rocket is not required for 300/350 kcmil).

## STEP 2

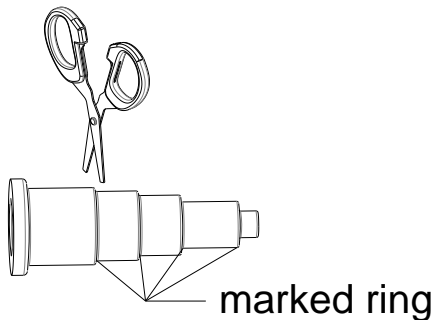

- Cut the rocket at the marked ring for #12 to 4/0.
- Reinsert the rocket. (if required)

## STEP 3

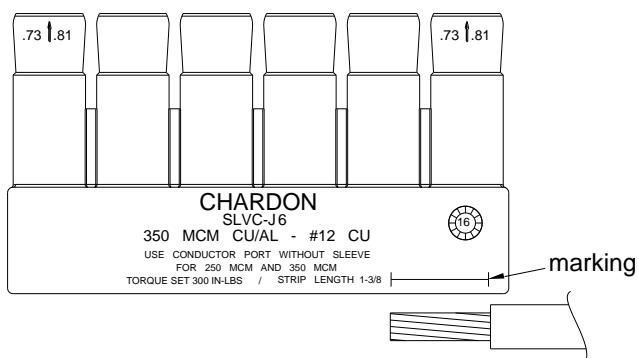

- Measure the strip length. Place the cable alongside the markings on the body, strip the cable.

## STEP 4

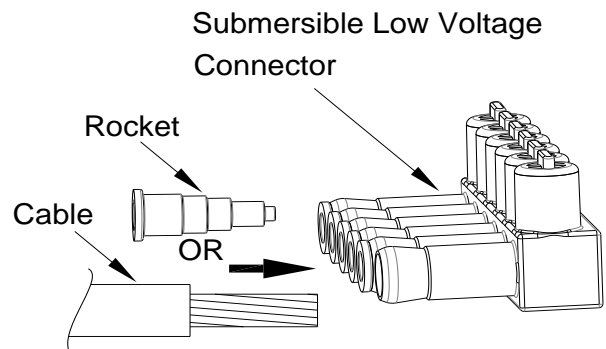

- Insert the cable into the tower (250 to 350 kcmil) or the rocket (#12 to 4/0) until the end of the conductor reach the end of the window.

## STEP 5

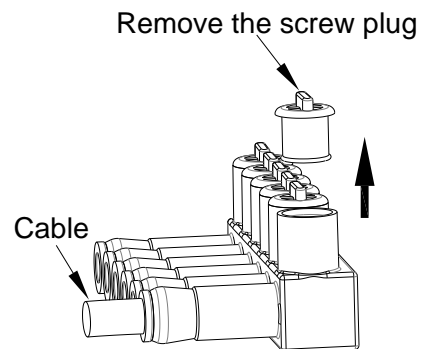

- Remove the screw plug

## STEP 6

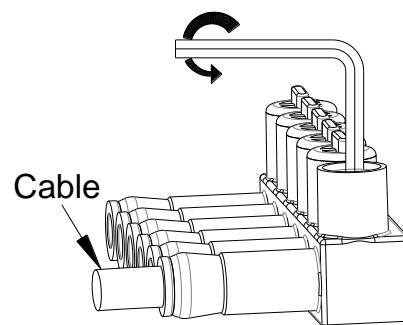

- Insert torque tool and rotate it. (120in-lb for #12 to #4, 240in-lb for #2 to 350kcmil)

## STEP 7

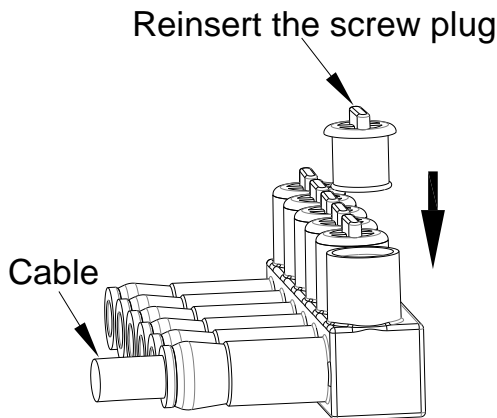

- Reinsert the screw plug

### IMPORTANT:



- Make sure all unused cable ports are sealed.
- When reinstalling a cable, it must be of the same size or larger than the one removed.
- Do not use in application exposed to sunlight for extended periods of time. Refer to the factory for these applications.

### SAFETY PRECAUTIONS:



- Follow standard safety practices when working on energized circuits.
- Insulating gloves rated to the appropriate voltage must be worn when installing on live conductors.
- Tap conductors may be installed on an energized main but IT MUST NOT BE UNDER LOAD.

**WARRANTY:** CHARDON sells this product with the understanding that the user will perform all necessary tests to determine the suitability of this product for the user's intended application. CHARDON warrants that this product will be free from defects in materials or workmanship for a period of two(2) years following the date of purchase. Upon prompt notification of any warranted defect, CHARDON will, at its option, repair or replace the defective product. misuse, misapplication or modification of CHARDON products immediately voids all warranties.

Inasmuch as CHARDON GROUP, Inc. has no control over the use which others may put the material, it does not guarantee that the same results as those described herein will be obtained, Each user of the material should make his own tests to determine the material's suitability for his own particular use. Statements concerning possible uses of the materials described herein are not to be construed as constituting a license under any CHARDON GROUP, inc. patent covering such use or as recommendations for use of such materials in the infringement of any patent.

FOR FURTHER INFORMATION WRITE TO



[sales@chardongroup.com](mailto:sales@chardongroup.com)